

Custom Architectural Designs' Torsion Spring Ceiling System is a full accessible system attached to a concealed carrier system that maintains exact panel alignment and a no reveal look. The swing down method allows for safe access to plenum areas. This system can accommodate a multitude of design ideas while still being easy to install.

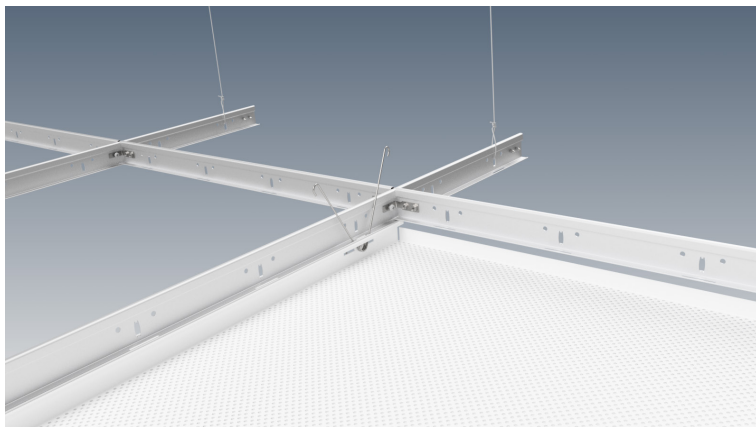

<b>Material</b>	Aluminum or galvanized steel (20-60% recycled content)
<b>Panel Size</b>	2'x2', 2'x4', 2'x6', and 2'x8', custom lengths and widths available upon request
<b>Color &amp; Finish</b>	Standard powder coat colors in white, silver, and grey in matte and semi-gloss finish
<b>Faux Wood</b>	Faux wood films available in 16 wood species
<b>Perforations</b>	Full line of perforations is available
<b>Acoustics</b>	Acoustical fleece and/or insulation
<b>Joints</b>	Butt joint and 1/8" reveal standard
<b>Substructure</b>	Slotted T-grid for interior and U-channel for exterior applications
<b>Perimeter Trim</b>	L-angle, shadow mold, C-channel, extruded trim are available
<b>System Height</b>	Approximately 4.5" plenum space required
<b>Weight</b>	Approximately 2 to 3 lbs/sq ft
<b>NRC</b>	Perforated panels NRC .65 — .90
<b>Fire</b>	ASTM E-84, Class A rating
<b>Sustainability</b>	Our finishes and substrates are all independently sourced from certified vendors.
<b>Warranty</b>	10-year warranty, 20-year warranty available with a life cycle of 30 years

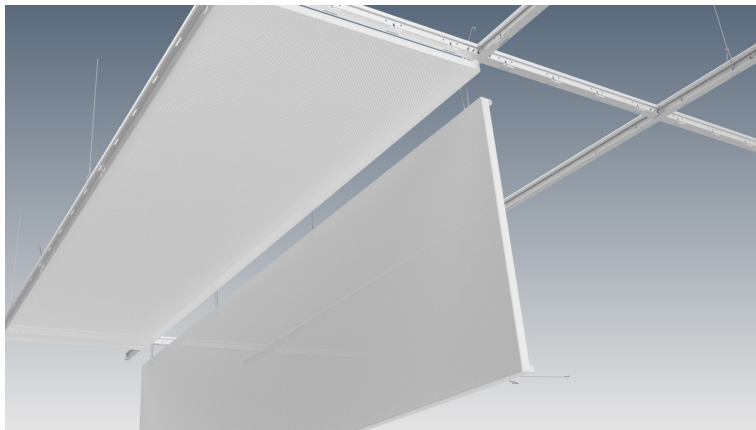

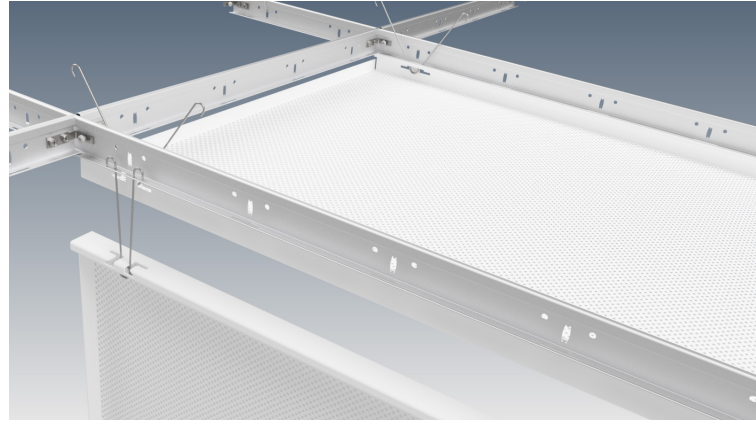
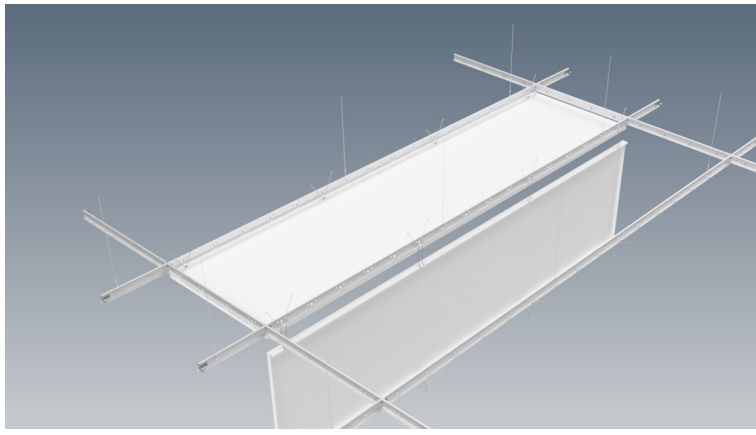

Custom Architectural Designs

1700 Maple Avenue SW, Rome, GA 30161 | [customarchitecturaldesigns.com](http://customarchitecturaldesigns.com)

UNPARALLELED DESIGN. UNMATCHED QUALITY.